

# V Series

## STANDARD ELECTRIC ACTUATORS

### With Speed Control/Timer Board (Option "J")

Installation, Maintenance and  
Operating Instructions

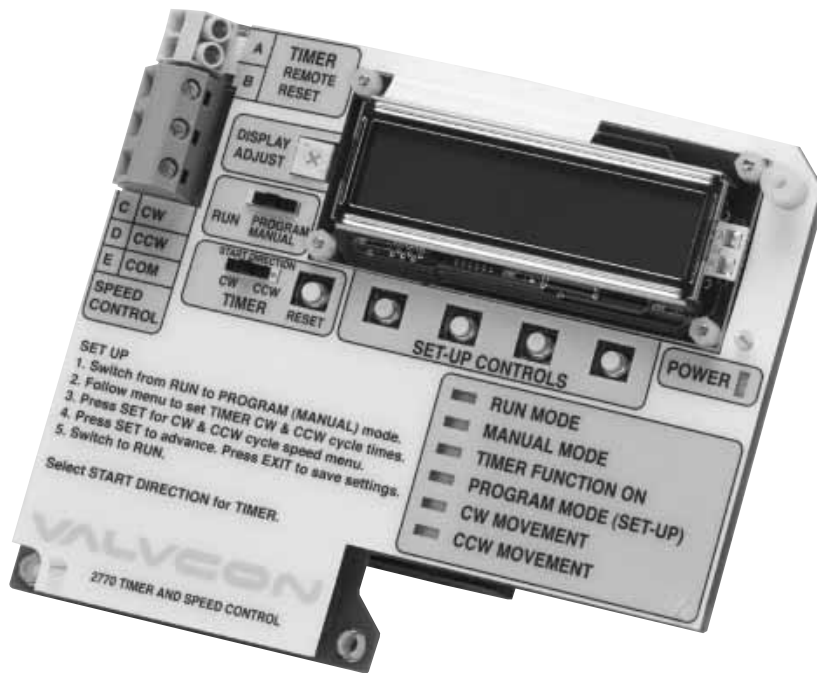

## Table of Contents

<b>1</b>	<b>GENERAL</b> .....	<b>3</b>
1.1	Description .....	3
1.2	Operation .....	3
1.2.1	Set-Up Procedure .....	3
<b>2</b>	<b>OPTION WIRING</b> .....	<b>4</b>
2.1	Motor Board Wiring .....	4
2.2	Timer Function Wiring .....	4
2.3	Speed Control Function Wiring .....	4
<b>3</b>	<b>V SERIES STANDARD OPTIONS</b> .....	<b>4</b>
3.1	Option "H" – Tropical Heater and Thermostat .	4
3.2	Option "I" – ISO 5211 Output .....	5
3.3	Option "K" – Mechanical Brake .....	5
3.4	Option "P" – Feedback Potentiometer .....	5
3.5	Option "S2" – Two Auxiliary Limit Switches . . .	5
3.6	Option "T" – Heater and Thermostat .....	6
3.7	Option "Z" – Handwheel Override .....	6
3.8	CSA Certification .....	6
3.9	Voltage .....	6
<b>4</b>	<b>GENERAL OPERATING INFORMATION</b> .....	<b>6</b>
4.1	NEMA Ratings and CSA Certification .....	6
4.2	Wiring .....	6
4.3	Duty Cycle and Motor Protection .....	6
4.4	Operating Temperature Limits .....	7
4.5	Actuator Mounting .....	7
4.6	Manual Override .....	7
4.7	Lubrication .....	7
4.8	Problem Prevention .....	7
4.9	Warranty .....	7
4.10	Technical Assistance .....	7
<b>5</b>	<b>SPECIFICATIONS &amp; TECHNICAL INFO</b> .....	<b>8</b>
5.1	Dimensions .....	9
5.2	Exploded View and Parts List .....	10
<b>6</b>	<b>V SERIES ACTUATORS BY PART NUMBERS</b> .....	<b>11</b>
<b>7</b>	<b>ADDITIONAL ACTUATOR PRODUCTS</b> .....	<b>12</b>

### READ THESE INSTRUCTIONS FIRST!

This instruction manual contains important information regarding the installation, operation, and troubleshooting of Metso Automation's V Series Option "J" Speed Control/Timer Board. Please read these instructions carefully and save them for future reference.

### SAVE THESE INSTRUCTIONS!

# 1 GENERAL

## 1.1 Description

This instruction manual provides detailed information on the setup and wiring of V Series Option “J” Speed Control/Timer Board. This board is a 115/230 VAC option that provides cycle speed regulation and/or automatic cycling operation.

The Speed Control feature solves the problem of the valve opening too quickly in fluid and steam applications where the resulting “hammer” or “shock” is eliminated. Both cycles, (CW and CCW) can be extended independently anywhere from the normal speed down to 1/200th the normal speed.

The Timer feature provides automatic cycling in On/Off applications where the actuation cycle can be scheduled anywhere from once every minute to once every 24 hours.

**This option will fit all V-Series 115 & 230 VAC actuators with the letter “N” preceding the voltage designator in the part number on the product nameplate.**

## 1.2 Operation

The Speed Control and Timer functions are both set up using the display (LCD) and pushbuttons.

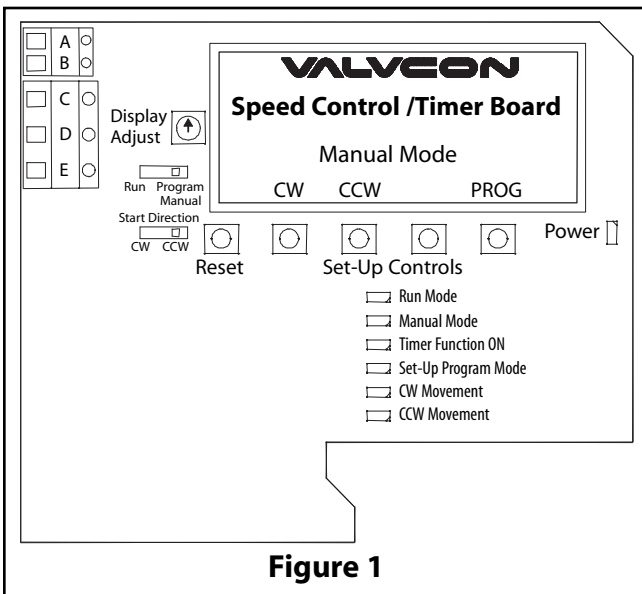

Figure 1

### 1.2.1 Set-Up Procedure

1. Select **[PROGRAM (MANUAL)]** mode using the slide switch. Note returning the slide switch to **[RUN]** at any time during programming will prompt user to press **[EXIT]** which will save any changes made in the programming session, (only applicable if **[SET]** button has been pressed).
2. Press the pushbutton under **[PROG]** on the display (LCD).

3. Press the pushbutton under **[START]** on the display (LCD).
4. Turn Timer function **[ON]** or **[OFF]** as desired with the corresponding pushbutton; press button under **[SET]** when finished. If no change to Timer setting; press pushbutton under **[SET]** to advance to next programming step. **If not utilizing Timer function, (i.e. Timer is OFF) press [SET] and proceed to Step 8 below.**
5. Select Timer **[START DIRECTION]** with the slide switch; this setting determines which cycle, (CW or CCW) the Timer function will start with if the **[RESET]** button is pressed or the **[REMOTE RESET]** is activated (or upon restoring power in a power loss condition).
6. Set CW Time:
  - A. Press **[+]** or **[-]** to increase or decrease HOUR setting.
  - B. Press **[NEXT]** to proceed to MINUTE setting.
  - C. Press **[+]** or **[-]** to increase or decrease MINUTE setting.
  - D. Press **[SET]** to proceed to CCW Time setup.
7. Set CCW Time:
  - A. Press **[+]** or **[-]** to increase or decrease HOUR setting.
  - B. Press **[NEXT]** to proceed to MINUTE setting.
  - C. Press **[+]** or **[-]** to increase or decrease MINUTE setting.
  - D. Press **[SET]** to proceed to Speed Control setup. **If not utilizing Speed Control function return slide switch to [RUN] position and press [EXIT] to complete programming.**
8. Set CW Cycle Speed:
  - A. Press **[+]** or **[-]** to increase or decrease speed ratio setting, (1:1 = Normal speed; 1:10 = 1/10th Normal speed).
  - B. Press **[SET]** to proceed to CCW Speed setup.
9. Set CCW Cycle Speed:
  - A. Press **[+]** or **[-]** to increase or decrease speed ratio setting, (1:1 = Normal speed; 1:10 = 1/10th Normal speed).
  - B. Press **[SET]** to return to Program Mode.
10. If desired, press **[REVIEW]** to review the program settings. Use **[SET]** button to advance.
11. Press **[EXIT]** when programming is completed and return slide switch to **[RUN]** position.

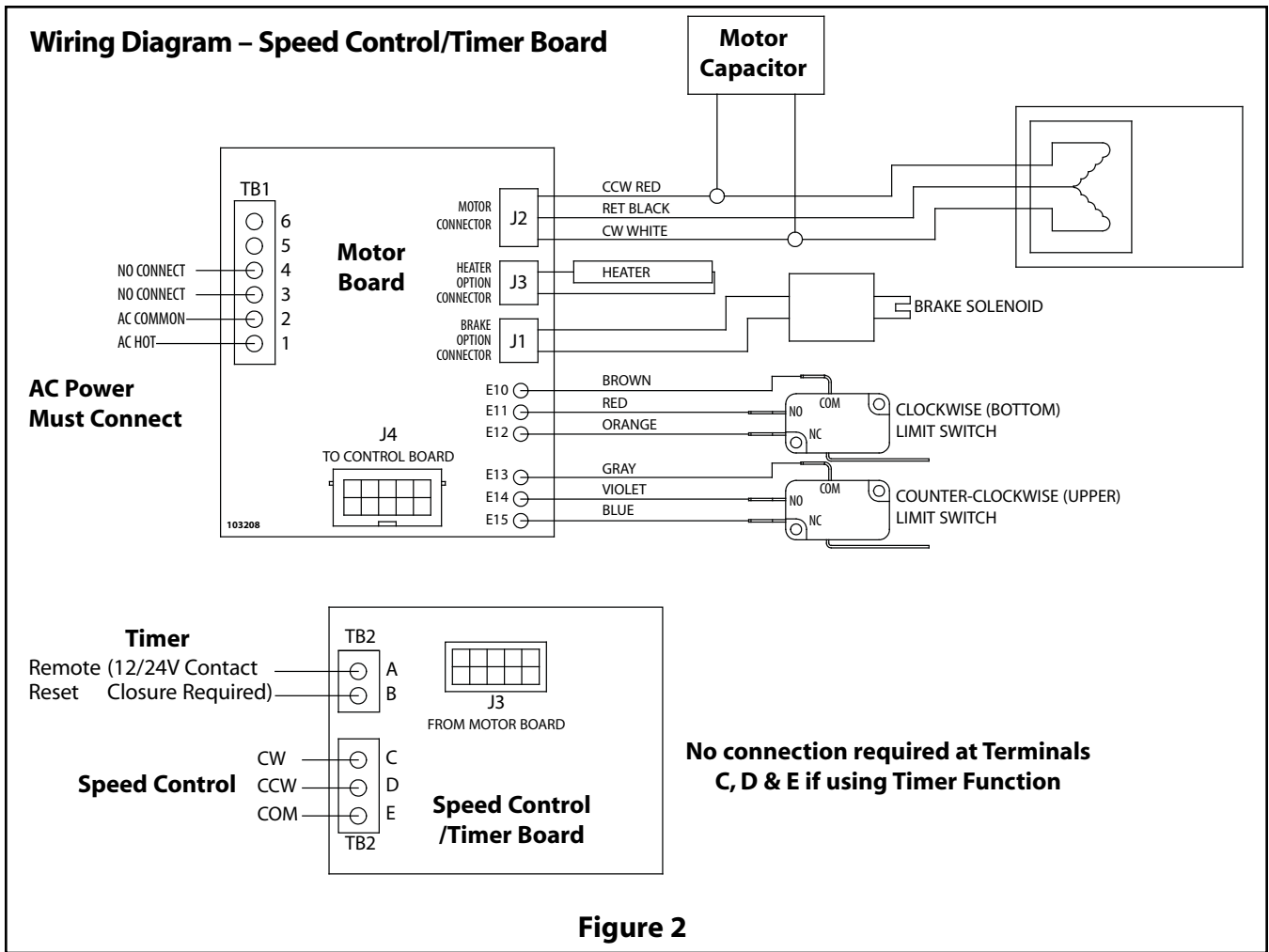

Figure 2

## 2 OPTION WIRING

Please consult the wiring diagram in **(Figure 2)** for specific connections and details.

### 2.1 Motor Board Wiring

In all applications Power **must** be applied to Motor Board, as follows:

- AC Hot (L2 in 230 VAC applications) to Terminal 1
- AC Common (L1 in 230 VAC applications) to Terminal 2

### 2.2 Timer Function Wiring

Wiring to the 2770 Speed Control/Timer Board is **not** required if utilizing the Timer function. Power is applied to the Motor Board only; the Timer will automatically control the cycling of the actuator per the settings entered by the user.

The Timer Reset feature may be activated remotely with a low-voltage, (12V or 24V) contact closure at Terminals A and B.

### 2.3 Speed Control Function Wiring

If using the Speed Control function with the Timer OFF, voltage **must** be applied to 2770 Speed Control/Timer Board, as follows:

- AC Hot (L2 in 230 VAC applications) to Terminal C to drive CW
- AC Hot (L2 in 230 VAC applications) to Terminal D to drive CCW
- AC Common (L1 in 230 VAC applications) to Terminal E

## 3 V SERIES STANDARD OPTIONS

All V Series options are designed to be easily installed in the field. Options for all standard V Series actuators are universal and completely interchangeable with each enclosure size. For additional V Series Options, see **(Table 3)**. Voltage is not field changeable.

### 3.1 Option “H” – Tropical Heater and Thermostat P/N 99716, P/N 99723

The tropical heater and thermostat option is a self-adhesive, resistance heater strip which is applied to the primary gear-

box. It installs with a plug-in connector and is recommended in high-humidity applications. The tropical heater option is also recommended in installations that experience wide temperature swings in order to evaporate any condensation. Thermostat is pre-set to activate at or below 90°F and deactivate at or above 110°F. The tropical heater draws 15 watts @ 115 VAC; 40 watts @ 230 VAC.

This option can be installed in the field; for 115 VAC applications, order kit **P/N 99716** and for 230 VAC applications order kit **P/N 99723**.

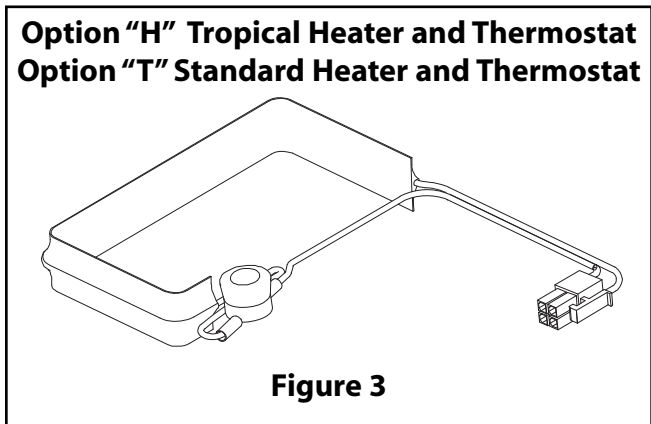

**Figure 3**

### 3.2 Option "I" – ISO 5211 Output

150 – 600 in•lb models are supplied with a 3/4" female square output coupling; when the "I" option is selected they are supplied with a 14 mm female square.

1000 – 3000 in•lb models are supplied with a 1" female square output coupling; when the "I" option is selected, 1000 in•lb models are supplied with a 19 mm female square and 1500 – 3000 in•lb models are supplied with a 22 mm female square.

This option is factory installed only.

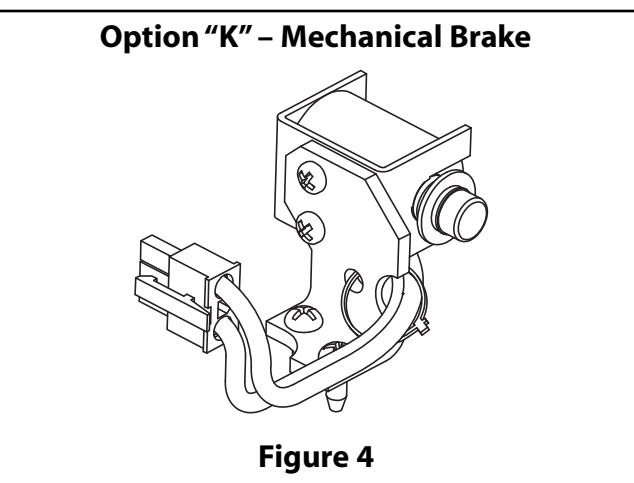

**Figure 4**

### 3.3 Option "K" – Mechanical Brake P/N 99715

The highly efficient hardened steel spur gear system requires that the brake option be installed on all butterfly valve and damper applications. It is also recommended on PVC ball valves and resilient seated valves. The brake will hold the valve in position against a force as great as the torque rating of the actuator. The brake option draws 4 watts and is universal to all standard V Series actuators.

It is simple to install with a plug-in connector and two philips head mounting screws. No additional brackets are required. This option can be installed in the field; order kit **P/N 99715**.

### 3.4 Option "P" – Feedback Potentiometer P/N 99200

The Feedback Potentiometer option provides 0 – 1000 Ohm resistance feedback and includes a 12 position terminal block for internal wiring.

This option can be installed in the field; order kit **P/N 99200**.

### 3.5 Option "S2" – Two Auxiliary Limit Switches P/N 99000

The extra switches and stainless steel cams provide dry contacts and are fully adjustable to trip at any position. They are often used for position indication or to interlock other devices (such as in sequencing operations). The switches are single pole, double throw switches rated for 1/2 HP, 15 amps @ 250 VAC, CSA certified. Auxiliary switch kit **P/N 99000** is universal to all standard V Series actuators and includes "flying wiring leads" for termination inside of the actuator enclosure using the supplied 6 position terminal block. This option can be installed in the field; order kit **P/N 99000**.

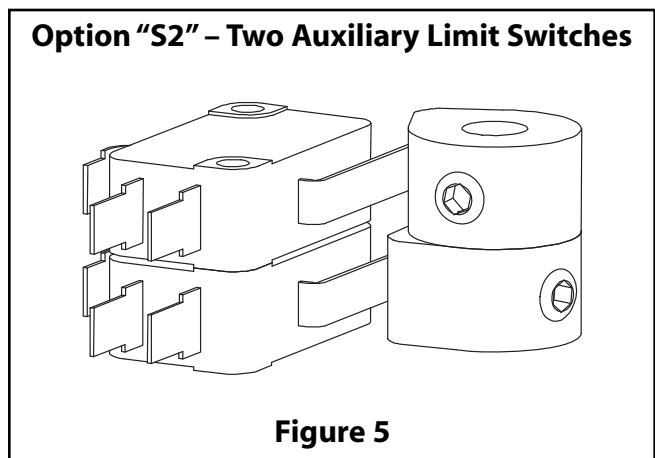

**Figure 5**

### 3.6 Option "T" – Heater and Thermostat P/N 99515, P/N 99523

The heater and thermostat option is a self-adhesive, resistance heater strip which is applied to the primary gearbox. It installs with a plug-in connector and is required in installations where the ambient temperatures drop below 32° F. The heater option is also recommended in installations that experience wide temperature swings in order to evaporate any condensation. Thermostat is pre-set to activate at or below 40° F and deactivate at or above 60° F. The heater draws 15 watts @ 115 VAC; 40 watts @ 230 VAC. This option can be installed in the field; for 115 VAC applications, order kit **P/N 99515** and for 230 VAC applications order kit **P/N 99523**.

### 3.7 Option "Z" – Handwheel Override

All V Series actuators are supplied with a wrench-operated manual override shaft. If the Handwheel Override option is selected the shaft is replaced by a declutchable shaft and a six-inch handwheel.

This option can also be installed in the field; for 150 – 600 in•lb models order kit **P/N 9097** and for 1000 – 3000 in•lb models order kit **P/N 9098**. See **(Page 7)** for Handwheel Override reference.

### 3.8 CSA Certification

CSA Certification is available after Q3 2008 on all standard V Series actuators for applications in either Hazardous (WX) or non-Hazardous (W) locations with the speed control/timer option. CSA certified actuators are identified by the CSA logo on the product label.

### 3.9 Voltage

115 VAC or 230 VAC. V Series actuators are rated for full torque at +/- 10% of the nominal voltage at 50 Hz or 60 Hz. At 50 Hz operation, the duty cycle decreases proportionally and the cycle time increase. V Series actuators are rated for a minimum of 75%\* duty cycle @ 60 Hz @ 104° F. They provide a 75% duty cycle and are rated for 50 Hz or 60 Hz as a standard feature.

\* 55% duty cycle for 3000 in•lb actuators.

## 4 GENERAL OPERATING INFORMATION

For enclosure specifications and dimensions, see **(Tables 1-2 and Figure 6)**

### 4.1 NEMA Ratings and CSA Certification

Metso Automation manufactures two styles of V-Series actuator enclosures: the "W" enclosure is weathertight and designed to NEMA 4/4X standards the "WX" enclosure is "explosionproof" and designed to NEMA 4/4X/7&9 (Class 1, Division 1, Groups C and D, Class 2, Division 1, Groups E, F and G and Class 3) standards.

Actuators are certified by CSA to meet Canadian and U.S. standards for applications in both Hazardous and Non-Hazardous locations. The "WX" option must be specified at the time of ordering and can only be installed at the factory. Ensure that the actuator's ratings are appropriate for the application environment prior to installation. Use extreme care when removing the cover. Scratches or nicks on the flanges may cause the enclosure not to meet NEMA or CSA specifications.

### 4.2 Wiring

Metso Automation AC voltage actuators use reversing induction motors which cause high voltages **Devices connected to terminal 3 and to terminal 4 must be rated for minimum 250 VAC (440 VAC for 230 VAC applications)**. Controllers with solid state outputs must be rated for more than 250 VAC. We strongly recommend that relay outputs be used on connected devices. Due to the induction feedback voltage, multiple actuators can not be wired in parallel. Separate (isolated contacts) must be provided for each actuator. If the actuator is driven by contacts on a PC or PLC, make sure the contacts have the proper ratings.

### 4.3 Duty Cycle and Motor Protection

V Series actuators can operate continuously for up to 15 minutes at 104° F. After 15 minutes of continuous operation they are rated for 75% duty cycle operation at 104° F and for 30 starts per minute. Duty cycles decrease at temperatures in excess of 104° F. Duty cycle is the maximum proportion of "on" time and the minimum required "off" time to prevent thermal overloading. Actuators with cycle times of 30 seconds must rest at least 10 seconds between cycles. Higher temperature applications decrease duty cycle.

Metso Automation's AC motors contain thermal overload protection. Exceeding the rated duty cycle may cause the thermal overload switch to temporarily remove power to the motor and cause it to stall. After the motor cools, the actuator will resume normal operation. The thermal protector is a safety device, designed for infrequent use. Constant tripping of the thermal overload protector may cause premature motor failure.

#### 4.4 Operating Temperature Limits

V Series actuators are designed to operate in ambient environments between 32°F and 150°F. If the ambient temperature may drop below 32°F, the heater and thermostat option must be installed. The actuator is rated to operate at -40°F with the heater and thermostat option installed. In outdoor applications where ambient temperatures exceed 80°F, actuators should be shielded from direct sunlight. In applications with high media temperatures, insulating blankets, heat shields and/or extended mounting shafts should be used to maintain ambient temperatures at the actuator within normal operating limits.

Heaters and thermostats are required for all outdoor applications and may also be used to dry condensation in high humidity environments.

#### 4.5 Actuator Mounting

The actuator may be mounted in any position including upside-down. It must be firmly secured to a direct mount flange or sturdy mounting bracket. A minimum of four bolts with lock washers should be used to secure the actuator to the bracket. Flexibility in the bracket is not allowed, and backlash, or "play", in the coupling should be minimized. The actuator output shaft must be in line (centered) with the valve shaft to avoid side-loading the shaft. See **(Figure 6)** for output drive dimensions and mounting hardware specifications.

#### 4.6 Manual Override

To use the manual override, push the override shaft down approximately 1/4 inch to disengage the motor from the gear train. Failure to disengage motor prior to turning override will cause damage to the actuator. While holding the shaft down, turn the shaft with a wrench or handle to the desired position. The override shaft on actuators below 1000 in•lb must be rotated in the opposite direction of the desired direction of the output shaft. In actuators 1000 in•lb and above, the override and the output shaft turn in the same direction.

Do not drive the actuator beyond the limit switch settings; it is possible to damage installed options such as a feedback potentiometer. The manual override shaft must be returned to its fully upward position before the motor is re-engaged. Rotate the shaft slightly to align the spur gears until the shaft "springs" back to its re-engaged position. **Note:** The rotation direction of the output may not be the same as the rotation of the override shaft!

#### 4.7 Lubrication

All rotating power train components are permanently lubricated with multi-purpose Lithium grease suitable for the operating temperature range of the actuator. Additional lubrication is not required in normal operation.

#### 4.8 Problem Prevention

Most actuator problems result from improper installation.

- **Incorrect Wiring and Set Up** Make certain the actuator is wired correctly and travel stops are properly set before power is applied.
- **Coupling, Alignment, and Mounting** Do not add extra torque! Make certain that the mounting arrangement is sturdy, centered, properly aligned, and that all mounting hardware is secure and properly tightened.
- **Moisture** Replace the cover tightly and make certain conduit entry holes are sealed properly to prevent moisture infiltration.

#### 4.9 Warranty

All V Series actuators are backed by a 2 year warranty that covers materials and workmanship.

#### 4.10 Technical Assistance, Replacement Parts, Options and Repairs

All replacement parts, plug-in options, accessories, and repair services for V Series actuators are available through a network of qualified Metso Automation Stocking Representatives. For further technical information or to locate the Metso Automation Stocking Representative closest to you, contact [www.valvcon.com](http://www.valvcon.com).

## 5 SPECIFICATIONS & TECHNICAL INFORMATION

Table 1 - Torque & VA Ratings								
Torque @ breakaway	Speed (seconds per 90° rotation)	Duty Cycle	VA Rating		Max Running Current at Full Load (True MS)		Max Effective Peak Inrush Current (= .66 x) Peak rush	
			115 VAC	230 VAC	115VAC	230 VAC	115 VAC	230 VAC
150 in•lb	8	75%	70 vA	115 vA	.6 amps	.5 amps	1.25 amps	.924 amps
300 in•lb	15	75%	70 vA	115 vA	.6 amps	.5 amps	1.25 amps	.924 amps
600 in•lb	30	75%	70 vA	115 vA	.6 amps	.5 amps	1.25 amps	.924 amps
1000 in•lb	25	75%	92 vA	161 vA	.8 amps	.7 amps	1.66 amps	1.29 amps
1500 in•lb	40	75%	92 vA	161 vA	.8 amps	.7 amps	1.66 amps	1.29 amps
2000 in•lb	55	75%	92 vA	161 vA	.8 amps	.7 amps	1.66 amps	1.29 amps
2500 in•lb	70	75%	92 vA	161 vA	.8 amps	.7 amps	1.66 amps	1.29 amps
3000 in•lb	75	55%	92 vA	161 vA	.8 amps	.7 amps	1.66 amps	1.29 amps

Table 2 - Specifications	
<b>Temperature Range</b>	32°F to 150°F (without heater and thermostat) -40°F to 150°F (with heater and thermostat)
<b>Conduit Connections</b>	(2) 3/4" NPT in sizes up to 600 in•lb (3/4" to 1/2" reducing bushings included) (2) 3/4" NPT in sizes 1000 in•lb and above (3/4" to 1/2" reducing bushings included)
<b>Output</b>	150 to 600 in•lb: ISO 5211 F05 and F07 bolt circles, 3/4" inch female square (14 mm w/"l" Option) 1000 in•lb and above: ISO 5211 F07 and F10 bolt circles, with 1" inch female square (19 mm 1000 in•lb, 22 mm 1500 – 3000 in•lb w/"l" Option)
<b>Duty Cycle</b>	The actuator may run continuously at temperatures below 104° F for up to 15 minutes. After that 15 minutes, the actuators may run up to 75% duty cycle (between each full cycle), the actuator must rest for 1/3 of the 90 degree cycle time. <b>NOTE:</b> At 50 Hz, the duty cycle is 60% @ 104° F.
<b>Voltage</b>	115 VAC: 103.5 to 126.5 VAC, 50 or 60 Hz 230 VAC: 207 to 253 VAC, 50 or 60 Hz
<b>Limit Switches</b>	<b>(2) Single pole, double throw switches rated for 1/2 HP, 15 amps @ 250 VAC, CSA certified, fuse protected.</b> Two standard switches are used for end of travel control, and for pilot or position indication at terminal 5 and terminal 6. Indication outputs are protected by 0.25 AMP permanent auto reset polyfuses – reset time approximately 3 mins.
<b>Motor</b>	Split phase, capacitor driven motor with Class B or better insulation; sub-fractional horsepower
<b>Lubrication</b>	Permanently lubricated gear train and bearings
<b>Gear Train</b>	Hardened steel spur gears
<b>Approximate Weight</b>	17 lbs for sizes up to 600 in•lb 31 lbs for sizes 1000 in•lb and above
<b>Enclosure</b>	Die cast aluminum



### 5.1 DIMENSIONS

OPTIONAL HAND WHEEL SHOWN

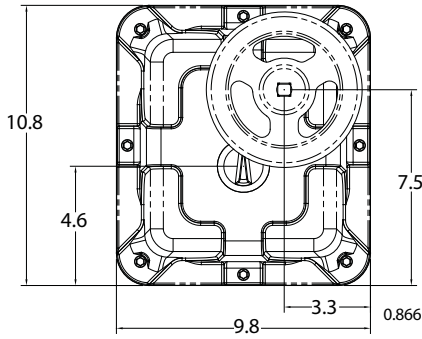

#### MOUNTING FLANGE, ISO 5211 F10/F07

4 X M8 - 1.25  $\nabla$  0.75" MIN.  
ON  $\varnothing$ 2.76" B.C.      4 X M10 - 1.5  $\nabla$  0.75" MIN.  
ON  $\varnothing$ 4.02" B.C.

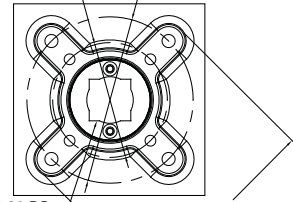

1.00 SQU. (Standard)  $\nabla$  1.20 DP.  
0.748 SQU. (19mm; Option I, 1000 in-lb)  
0.866 SQU. (22mm; Option I, 1500-3000 in-lb)

**ISO 5211 F10/F07  
Bolt Circles Standard**

ALL DIMENSIONS IN INCHES

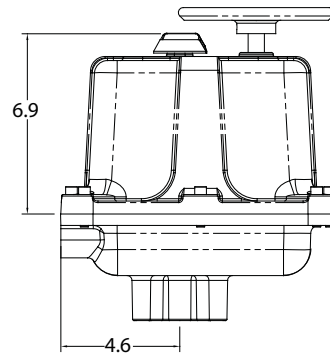
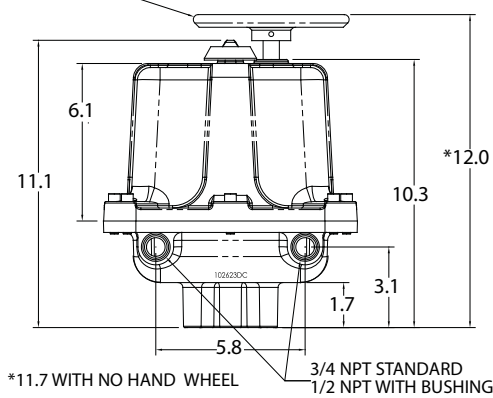

\*11.7 WITH NO HAND WHEEL  
3/4 NPT STANDARD  
1/2 NPT WITH BUSHING

102623

OPTIONAL HAND WHEEL SHOWN

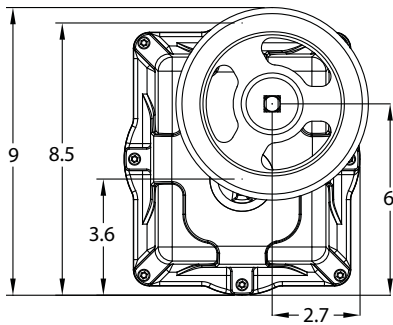

#### MOUNTING FLANGE, ISO 5211 F07/F05

4 X M6 - 1.0  $\nabla$  0.75" MIN.  
ON  $\varnothing$ 2.0" B.C.      4 X M8 - 1.0  $\nabla$  0.75" MIN.  
ON  $\varnothing$ 2.0" B.C.

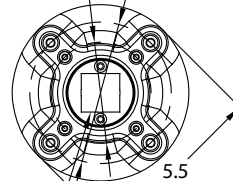

0.75 SQU. (Standard)  $\nabla$  0.9"  
0.551" SQU. (14mm; I Option)

**ISO 5211 F07/F05  
Bolt Circles Standard**

ALL DIMENSIONS IN INCHES

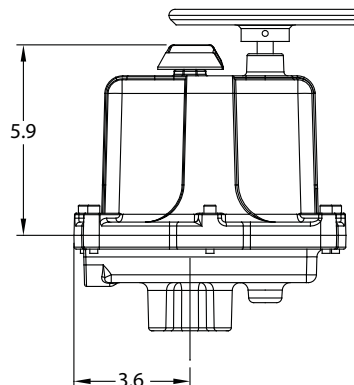
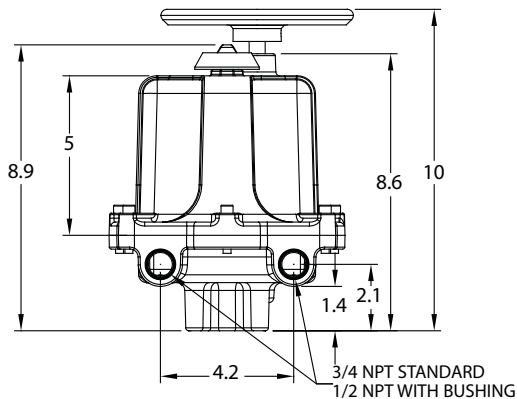

\*10 WITH NO HAND WHEEL  
3/4 NPT STANDARD  
1/2 NPT WITH BUSHING

102652

**Figure 6**

**5.2 EXPLODED VIEW**

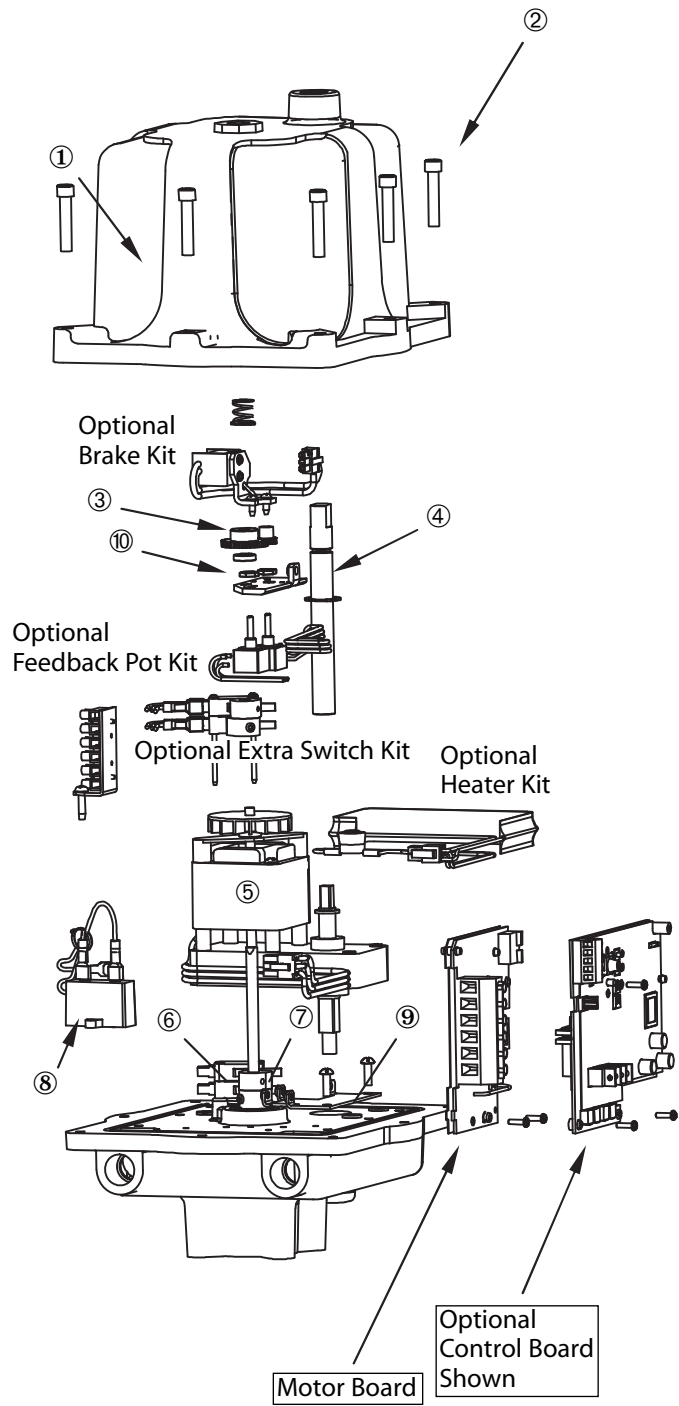

**V SERIES SPARE PARTS LIST**

Item No.	Part No.	Description
1	9302	Cover with Position Indicator
	9301	Small enclosure (150 – 600 in•lb) Large enclosure (1000 – 3000 in•lb)
2	91340	Cover screw
	91336	Small NEMA 4/4X enclosure (150 – 600 in•lb)
	91564	Small NEMA 4/4X/7&9 enclosure (150 – 600 in•lb) Large enclosure (1000 – 3000 in•lb)
3	99090	Potentiometer/Cam Shaft Gears
	99180	90 degree Operation
	99270	180 degree Operation 270 degree Operation
4	91244	Override shaft (replacement only)
	93023	Small enclosure (150 – 600 in•lb) Large enclosure (1000 – 3000 in•lb)
5	90101	Motor Gearbox
	90102	115 VAC, 150 – 300 in•lb
	90201	115 VAC, 600 in•lb
	90103	115 VAC, 1000 – 3000 in•lb
	90104	230 VAC, 150 – 300 in•lb
	90202	230 VAC, 600 in•lb 230 VAC, 1000 – 3000 in•lb
6	1020	Limit Switch
7	91352	Cam with set screw
8	93041	Capacitor
	93061	115 VAC, 150 – 600 in•lb
	93051	115 VAC, 1000 – 3000 in•lb
	93071	230 VAC, 150 – 600 in•lb 230 VAC, 1000 – 3000 in•lb
9	91695	Bracket, mounting, motor board w/screws
	91698	Small enclosure (150 – 600 in•lb) Large enclosure (1000 – 3000 in•lb)
10	91684	Bracket, motor board, upper
	91688	Small enclosure (150 – 600 in•lb) Large enclosure (1000 – 3000 in•lb)
	92015	Motor board with screws
	92030	115 VAC 230 VAC

**V SERIES OPTION KITS**

Item No.	Part No.	Description
	99715	Brake (ALL)
	99200	Feedback pot (ALL)
	99000	Extra limit switch (ALL)
	99515	Heater Thermostat 115 VAC (ALL)
	99523	Heater Thermostat 230 VAC (ALL)
	99642	Control Board (ALL)
	92065	Iso/Readback Board
		Hand-wheel Override
	9097	Small enclosure (150 – 600 in•lb)
	9098	Large enclosure (1000 – 3000 in•lb)
	99716	Tropical Heater/Thermostat 115 VAC
	99723	Tropical Heater/Thermostat 230 VAC

**Figure 7**

## 6 V SERIES ACTUATORS BY PART NUMBERS

Series	Enclosure Type		Torque		Board Options <sup>1</sup>		Other Options		Operating Voltage		
	Code	Description	Code	Description	Code	Description	Code	Description	Code	Description	
V	W	Weathertight NEMA 4/4X	150	150 in·lb	C	Control Board	H <sup>2</sup>	Tropical Heater/Thermostat	N115AC	115 VAC	
			300	300 in·lb	J	Speed Control/Timer Board	I <sup>3a</sup>	ISO 5211 Output	N230AC	230 VAC	
			600	600 in·lb	U	ISO Readback Board	K	Brake			
	WX	Weathertight & Explosionproof NEMA 4/4X/7&9					P	Feedback Potentiometer			
							S2	Two Auxiliary Limit Switches			
							T <sup>4</sup>	Heater/Thermostat			
							Z	Handwheel			
LV	W	Weathertight NEMA 4/4X	1000	1000 in·lb	C	Control Board	H <sup>2</sup>	Tropical Heater/Thermostat	N115AC	115 VAC	
			1500	1500 in·lb	J	Speed Control/Timer Board	I <sup>3b</sup>	ISO 5211 Output	N230AC	230 VAC	
			2000	2000 in·lb	U	ISO Readback Board	K	Brake			
		WX	Weathertight & Explosionproof NEMA 4/4X/7&9	2500	2500 in·lb			P	Feedback Potentiometer		
				3000	3000 in·lb			S2	Two Auxiliary Limit Switches		
								T <sup>4</sup>	Heater/Thermostat		
							Z	Handwheel			

- Notes: 1. Select only one board option, as needed.
2. This heater option activates at or below 90°F and deactivates at 110°F; it is recommended in high-humidity applications.
- 3a. 150 – 600 in·lb models with "I" option are supplied with a 14 mm female square (note that without option "I" the female square is 3/4")
- 3b. 1000 in·lb models with "I" option are supplied with a 19 mm female square and 1500 – 3000 in·lb models are supplied with a 22 mm female square (note that without option "I" the female square is 1")
4. This heater option activates at or below 40°F and deactivates at 60°F; it is recommended in applications where the temperature may drop below 32°F.

For enclosure specifications and dimensions see (Tables 12 and Figure 6).

- **Enclosure "W"** (weathertight) is certified by CSA to meet specifications for NEMA 4/4X for weathertight and dusttight, environments. It is intended for non-hazardous locations in indoor or outdoor use and provides a degree of protection against corrosion, windblown dust and rain, splashing water, hose-directed water, and damage from external ice formation. It is not designed to be submersible.
- **Enclosure "WX"** (explosionproof & weathertight) is certified by CSA to meet specifications for NEMA 7&9, explosionproof environments as well as to meet NEMA 4/4X specifications. Explosionproof means that an internal explosion will be contained, with no sparking that could ignite external atmospheric gases. The enclosure is rated for the following environments:

NEMA Class I, Division 1, Group C (Ehtyl-ether vapors, ethylene or cyclopropane)

NEMA Class I, Division 1, Group D (Gasoline, hexane, naptha, benzene, butane, propane, alcohol, acetone, benzol, lacquer, solvent, vapors or natural gas)

NEMA Class II, Division 1, Group E (Metal dust, including aluminum, magnesium, their commercial alloys, and other metals of similarly hazardous characteristics)

NEMA Class II, Division 1, Group F (Carbon black, coal or coke dust)

NEMA Class II, Division 1, Group G (Flour, starch or grain dust)

NEMA Class III

### Sample Model Code: LVW1500CHIKS2N230AC

Actuator Series	LV
Enclosure Type	W
Torque	1500
Board Option	C
Other Options (if applicable)	H I K S2
Operating Voltage	N230AC

- **Torque = Breakaway Torque** Valvcon actuators are rated at breakaway torque; the amount of torque the actuator will provide from a fully loaded stop upon immediate power-up. With running momentum and inertia, the amount of torque supplied by the actuator at full speed (running torque) or upon entering a stall condition (stall torque) always exceeds the minimum rated breakaway torque. Since valves require most torque at breakaway, only breakaway torque should be considered when sizing actuators.

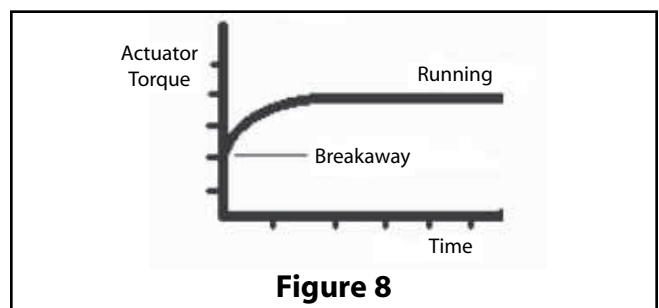

Figure 8

## 7 ADDITIONAL ACTUATOR PRODUCTS AND ACCESSORIES FROM VALVCON

Ask For Information About the Wide Range of other Valvcon Electric Actuators.

- "LC" Series for low cost On/Off Applications
  - Torque Up to 600 in•lb
  - 25% Duty Cycle
  - NEMA 4/4X Enclosures
  - 115VAC, 230VAC, 24VAC, 12VDC, and 24VDC voltages
  - Options Include Extra Limit Switches and Heater/Thermostat
  - Male output (standard) or female output (optional)
- "ADC" and "ESR" Series for Fail-Safe (Loss of Power) Applications
  - ADC – Fail-Safe Torque Up to 3000 in•lb, Internal Battery Pack for ON/OFF and Continuous Duty Modulating Applications
  - ESR – Up to 600 in•lb, True Two Wire Operation - Energize to Drive, De-energize to Return.
- "Q6" Series for Remote Solar Powered Applications
  - Torque Up to 600 in•lb
  - 12VDC
  - Low Current Draw
- "I" Series Network Capable Electric Actuators For 2 Wire Bus Protocols
  - AS-interface
  - LonWorks
  - DeviceNet
  - MODBUS
  - Foundation Fieldbus
  - Profibus

Subject to change without prior notice.

### Metso Automation, Flow Control

**Europe**, Levytie 6, P.O.Box 310, 00811 Helsinki, Finland. Tel. int. +358 20 483 150. Fax int. +358 20 483 151

**North America**, 28 Bowditch Drive, P.O.Box 8044, Shrewsbury, Massachusetts, 01545-8044 USA. Tel. int. +1 508 595 5083. Fax int. +1 508 595 5183

[www.valvcon.com](http://www.valvcon.com)

