



# PROMATION ENGINEERING

Precision Actuation for Industry  
...Partners, Above and Beyond

Data Sheet

## P4/5 HV AC Series

On/Off/Jog/Proportional  
ISO5211 F10 8P35

Actuator Specifications	P4		P5	
	3500"lbs / 400Nm		4400"lbs / 500Nm	
Torque lb/Nm	3500"lbs / 400Nm		4400"lbs / 500Nm	
Supply Voltage	120vac	230vac	120vac	230vac
Max Inrush Current	3.1A	1.5A	3.0A	1.5A
Running Current	1.3A	0.6A	1.5A	0.7A
Runtime (90°@60/50Hz)	16sec/18sec		22sec/25sec	
Weight	49lbs/22kg			
Mechanical Connections	ISO5211 F10 8 pt 35mm			
Electrical Entry	(2) 3/4" NPT			
Electrical Terminations	12 - 18 Ga.			
Environmental Rating	4, 4X			
Manual Override	7.6" HandWheel			
Control	On/Off/Jog/Proportional			
Duty Cycle	See Graph Below			
Case material	Aluminum Alloy, Powder Coated			
Motor Protection	Split Phase Capacitor			
120/230vac Operation	275°F/135°C Thermal F Class			
Motor Protection	DC Brush Type			
12/24v (AC) Operation	275°F/135°C Thermal F Class			
Ambient Temperature	-22°F to +150°F			
Operating Range	-30°C to +65°C			



An electric actuator designed for load requirements ranging from 3500 to 4400"lbs. The actuator comes standard with two auxiliary switches (Form C), an internal low power heater, a NEMA 4X environmental rating, and in 120vac or 230vac supply voltages. The P4/5 mechanical connections utilize an ISO5211 mounting system. The P4/5 Series can be ordered as an on/off or two position model that can also be used in bump/jog applications. Or it can be ordered with an advanced internal proportional control card that accepts a wide range of control signals, generates multiple feedback signals, and has look-ahead fault prevention.

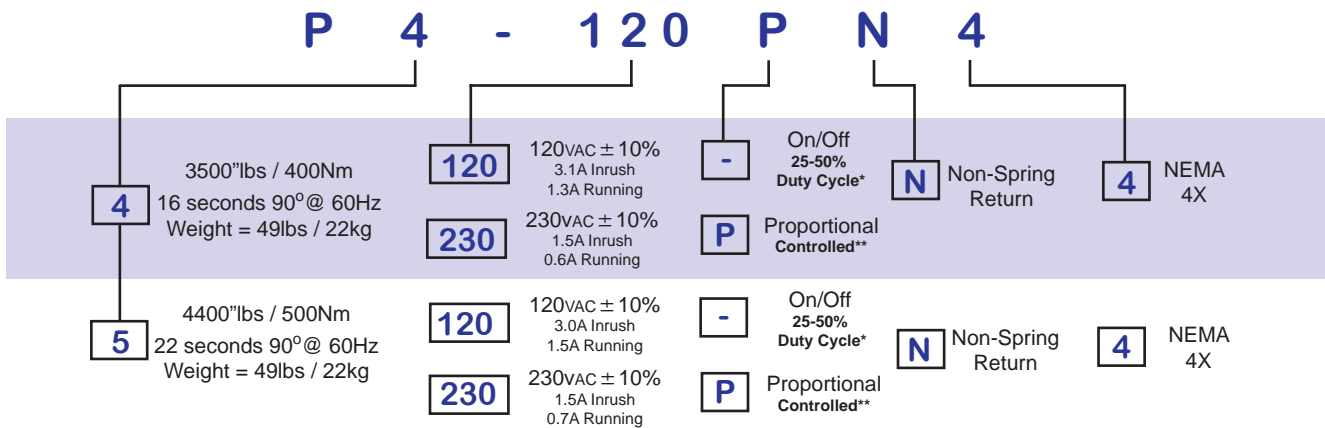

SD08\_P45F108P35 HV AC Ver D 121808

CSA Certified Duty Cycle Graph

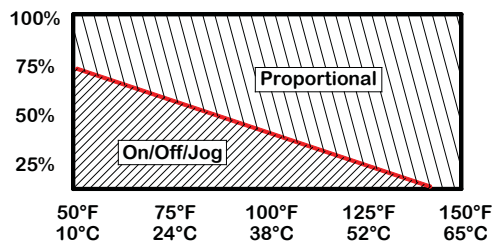

\* Duty cycle is defined as the ratio of run time vs. off time and is a function of ambient temperature.

\*\* Controlled Duty cycle is a proprietary function. (Please contact your local distributor for information)

See Pg 4 for Options

Also available in 12V & 24V AC or DC operation, and in 3 phase models for 230/3/60, 380/3/60 & 480/3/60 supplies. Separate spec sheets are available for these configurations.



## Application Notes:

1. These actuators are designed to be used in either a horizontal or upright position.  
Do NOT mount the actuator with the top below a horizontal position.
2. When installing conduit, use proper techniques for entry into the actuator. Use drip loops to prevent conduit condensate from entering the actuator.
3. Both NPT conduit ports MUST use proper equipment to protect the NEMA 4x integrity of the housing.
4. The internal heater is to be used in ALL applications.
5. Do NOT install the actuator outdoors or in humid environments unless it is powered up and the heater is functioning.
6. Use proper wire size to prevent actuator failure (see chart below for proper wire sizing).
7. Mechanical travel stops are factory calibrated for 90 degree operation. These stops are NOT designed to adjust mechanical rotation by more than +/- 3 degrees.

## P4/5 Series Dimensional Data

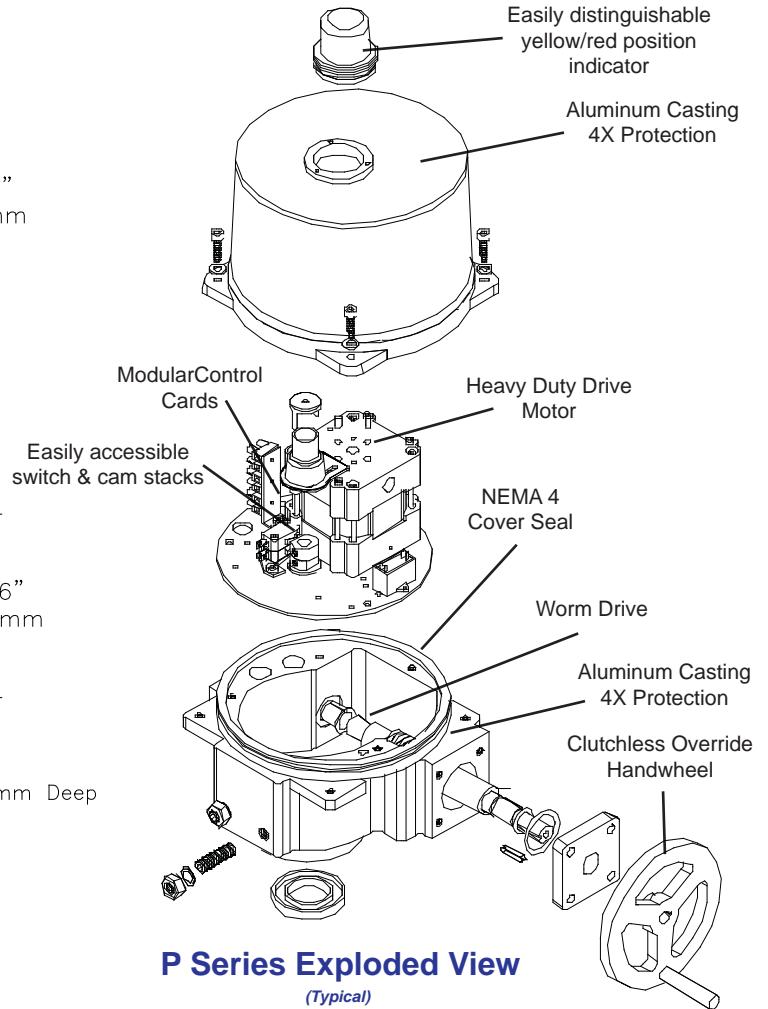
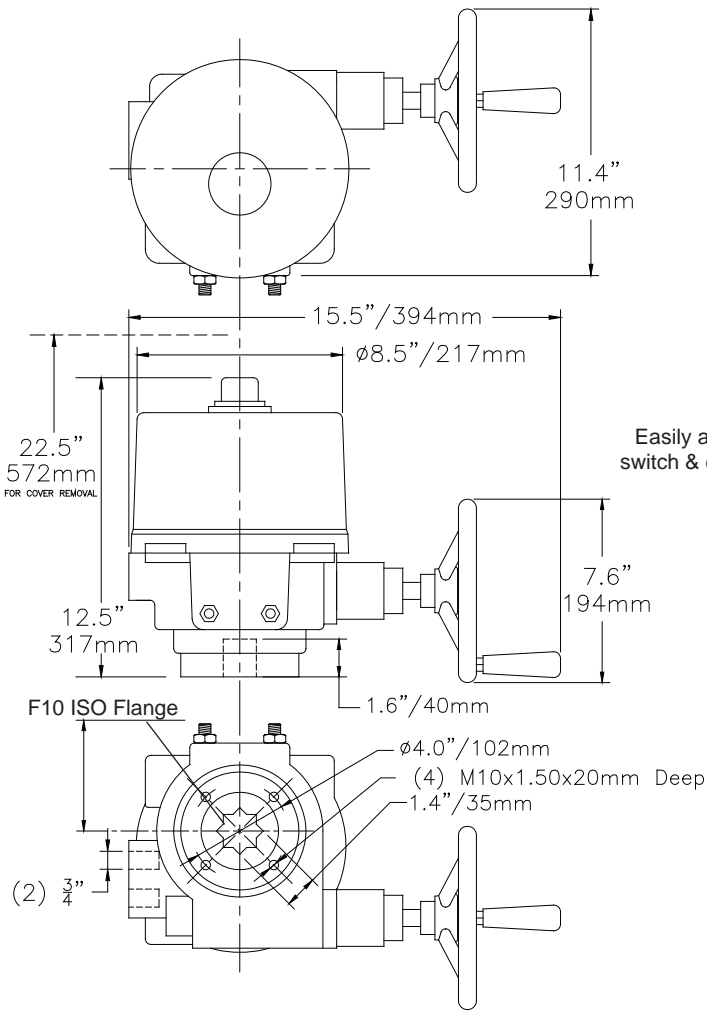

Wire sizing data is provided in the table below to assist in the selection of the proper wire size for ProMation P4/5 series actuators using various wire sizes over distance. Please make sure to reference the correct voltage and do not exceed the indicated length of the wire run for each model.

## Wire Sizing Data

MAX distance between Actuator and Supply (feet)		
Wire Gage	P4/5-120 3.1A	P4/5-230 1.5A
18	267	1056
16	419	1659
14	677	2681
12	1035	4100
10	1760	6970
8	2626	10403

Switch sequencing data is provided in the table below to show the change-of-state points during the rotation of the actuator from OPEN to CLOSED and back again. Switches for terminals 3 thru 6 are set at the factory and should NOT be changed. The INCLUDED auxiliary switches SW3 & SW4 are for terminals 7 thru 12 and those setpoints may be modified if need be. When so optioned, SW5 & SW6 auxiliary switches are initially set to function the same as auxiliary switches SW3 & SW4.

## Switch Logic Map and Switch/Cam Arrangement

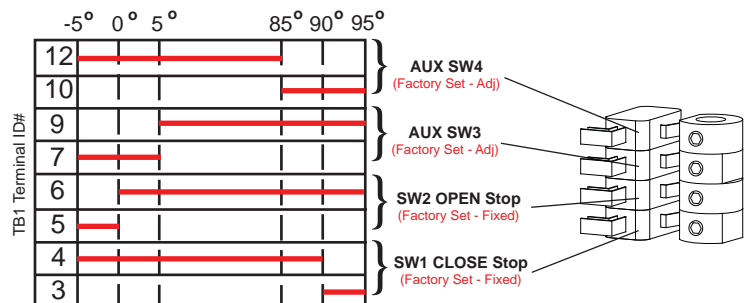

# Wiring Diagrams for P Series -

## On/Off/Jog Control

Field Control Device may be relay contact, Switch or Triac type. Pilot device 10A MAX. Auxiliary switches are rated 10A @ 250vac MAX. Terminals 7-12 are dry type Form C. Terminals accept 12-18ga solid/stranded wire.

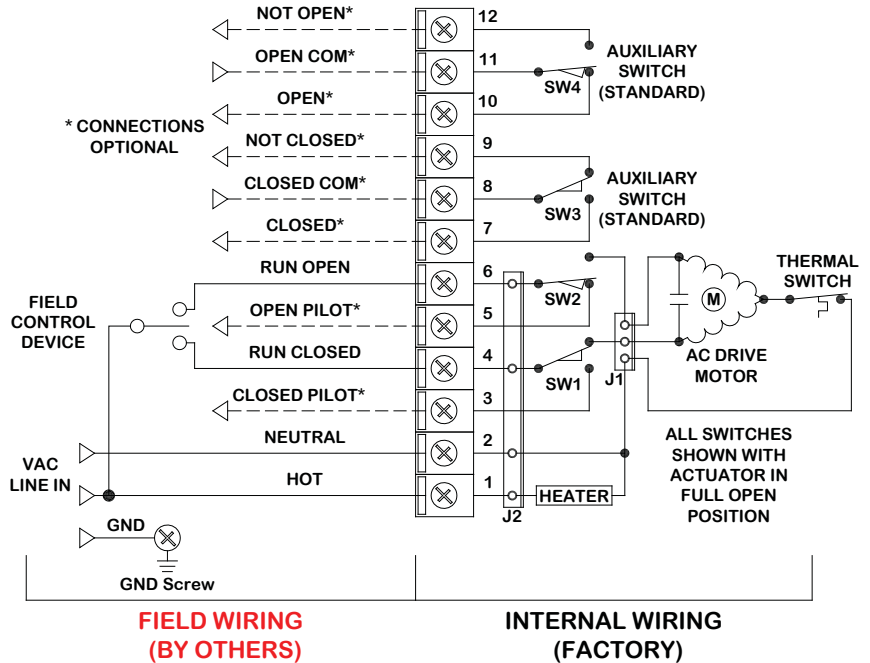

*Pertains to 120vac & 230vac models.*

Control Signal Inputs (selectable and programmable):  
0-10vdc, 1-5vdc, 2-10vdc, 0-20mA, 4-20mA

Common can be ground referenced or isolated from ground.

Input impedance: 135k ohms (0-10vdc)  
250k ohms (0-5vdc)  
250 ohms (4-20mA)

Sensitivity: 50mV (0-10vdc)  
20mV (1-5vdc)  
80uA (4-20mA)

Feedback Signal Output (selectable and programmable):

1-5vdc, 0-10vdc, 2-10vdc, 4-20mA  
Referenced to the common terminal.  
Max Load: 500 ohms

Alarm contacts and PWR FAIL connections are detailed in the [PEI Controller Manual](#).

Main Switch Card Terminals accept 12-18ga solid/stranded wire.

Proportional Control Card Terminals accept 14-22ga solid/stranded wire.

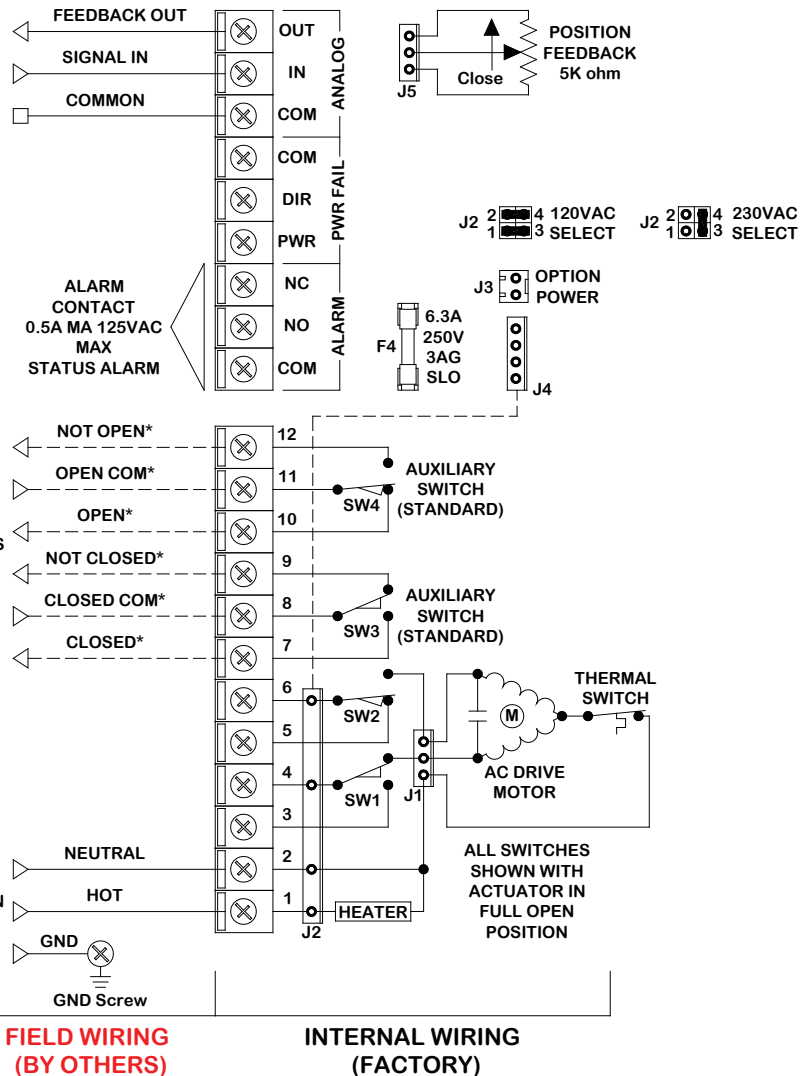

SD08\_P45F108P35 HV AC Ver D 121808

## Local Control Options



**LA**

Basic Version  
No indicator lamps  
No remote status outputs  
No aux switch pass-through

**LB**

Mid-Level Version  
2 status indicator lamps  
2 status HOT outputs  
No aux switch pass-through

**LC**

Full Version  
4 status indicator lamps  
Remote status monitoring  
Aux switch termination block

## +2 Auxiliary Switch Option

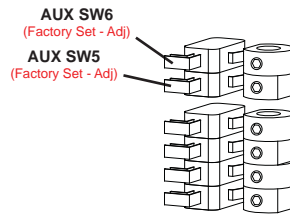

Switch/Cam  
Arrangement

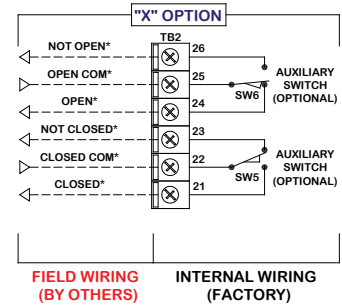

The **X Option** consists of 3rd & 4th auxiliary switches factory mounted. This is NOT a field installed option. This option can be used with On/Off and Proportional control actuators. It is available on P2 thru P13 series actuators, and must be ordered with actuator.

## Potentiometric Feedback Option

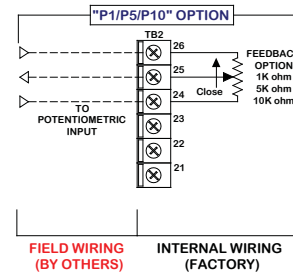

The **P# Option** is a potentiometric feedback for On/Off actuators. This is NOT a field installed option. This option can be used only with On/Off actuators. It is available on P2 thru P13 series actuators. This option requires the selection of 1k, 5k or 10k ohm resistance values, and must be ordered with actuator.

## Chain Wheel Options

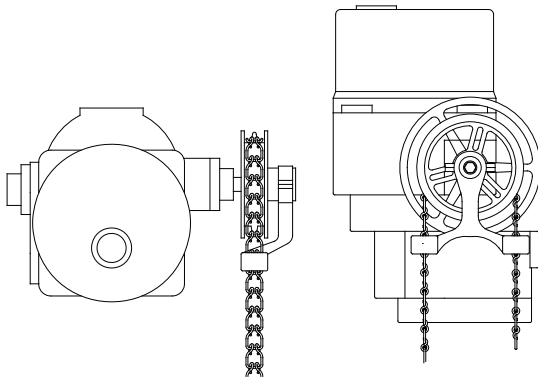

The **C Option** is a mechanical Chain Wheel system that converts the manual override handwheel to a chain driven override for use in applications where the actuator is mounted at a distance above the floor. (Must be used with one of the above Local Control Options, see the options guide for details)

These tables indicate which options are available in On/Off and Proportional control actuators, as well as which options are compatible with each other.

Proportional Options Compatibility			
	C	L	X
C	-	yes	yes
L	yes	-	yes
X	yes	yes	-

On/Off Options Compatibility				
	C	L	X	P1,5,10
C	-	yes	yes	yes
L	yes	-	yes	yes
X	yes	yes	-	n/a
P1,5,10	yes	yes	n/a	-



**PROMATION  
ENGINEERING**

Precision Actuation for Industry